

# **PARKRAY**

**THE FIRST NAME IN SOLID FUEL**



## **C O N S O R T 1 5 C E**

### **M U L T I F U E L C E N T R A L - H E A T I N G S T O V E**

#### **Installation and Operating Instructions**

**An accredited competent person must carry out the installation of this appliance; alternatively, your local Building Control Officer can approve the completed installation, should a non-accredited engineer undertake the installation. It is an offence, under UK law, not to comply with this advice. Please hand these instructions to the stove user when the installation is complete. Leave the system ready for operation and instruct the user in the correct use of the appliance and operation of controls.**



## Consort 15 CE Central-Heating Technical Specification

Stove Mass 163 kg

### Wood

Total Efficiency	73.6%
Nominal Heat Output	14 KW
Output to Water	8.7 KW
Output to Room	5.3 KW
Mean CO Emission (at 13% O <sub>2</sub> )	0.74 %
Mean Flue Gas Temperature	313 °C
Flue Gas Mass Flow	12.2 g/s
Nominal Flow Rate	2.5 litres/minute

### Ancit

Total Efficiency	70.0 %
Nominal Heat Output	14 KW
Output to Water	10.3 KW
Output to Room	3.7 KW
Mean CO Emission (at 13% O <sub>2</sub> )	0.30 %
Mean Flue Gas Temperature	314 °C
Flue Gas Mass Flow	12.9 g/s
Nominal Flow Rate	3.5 litres/minute

This appliance is not suitable for use in a shared flue

This appliance is suitable for continuous burning



## Assembly Instructions

### PLEASE READ THESE INSTRUCTIONS CAREFULLY

It is important that your stove is correctly installed, as Parkray Limited cannot accept responsibility for any fault arising through incorrect use or installation.

#### **Important Warning**

This stove must **not** be installed into a chimney that serves any other heating appliance. There must **not** be an extractor fan fitted in the same room as the stove as this can cause the stove to emit fumes into the room.

#### **Flue Collar**

Place the Flue Gasket on the top or rear outlet as required. Place the Flue Collar on top of the Gasket. Secure to the four locating tabs, inside the flue outlet, using the M6 bolts supplied. Fit the 2 - M8 carriage bolts, washers & nuts into the Damper Holes, located on each side of the Flue Collar.

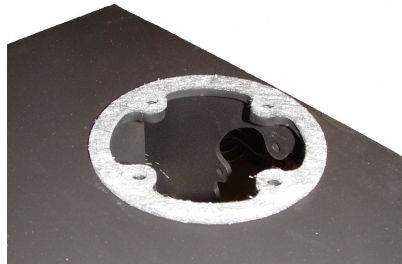

#### **Blanking Plate**

Fit the Flue Gasket and Blanking Plate on the remaining free outlet and secure it, using 4 - M6 screws.



#### **Fire Bricks**

The Fire Bricks, in this appliance, are factory fitted. The following set of photos show the removal sequence that you will need to employ when servicing your Parkray stove.

#### **Baffle Brick**



Remove the four furthest grate bars on the left-hand side. Lift the Baffle Brick and slide to the right. When the left side of the Brick clears the Baffle Support, lower the Brick into the Fire Box and remove.



## **Installation Instructions**

READ THESE INSTRUCTIONS CAREFULLY BEFORE INSTALLATION

These instructions cover the basic principles to ensure satisfactory installation of the stove, although detail may need slight modification to suit particular local site conditions. In all cases the installation must comply with current Building Regulations, Local Authority Byelaws, European and national standards and other specifications or regulations as they affect the installation of the stove. It should be noted that the Building Regulations requirements may be met by adopting the relevant recommendations given in British Standards BS 8303, BS 6461 and BS 7566 as an alternative means to achieve an equivalent level of performance to that obtained following the guidance given in Approved Document J.

### **Competent Persons Scheme**

Members of the following schemes may self-certify the installation of this stove. If the installer is not a member of one of these schemes, your local building control department must approve the installation.

<b>Scheme</b>	<b>Web address</b>	<b>Telephone</b>
APHC (Association of Plumbing and Heating Contractors (Certification) Limited)	<a href="http://www.aphc.co.uk">www.aphc.co.uk</a>	02476 470 626
Building Engineering Services Competence Accreditation (BESCA Limited)	<a href="http://www.hvca.org.uk">www.hvca.org.uk</a> / <a href="http://www.besca.org.uk">www.besca.org.uk</a>	0800 652 5533
HETAS Ltd (Heating Equipment Testing and Approval Scheme)	<a href="http://www.hetas.co.uk">www.hetas.co.uk</a>	01462 634721
NAPIT Registration Ltd	<a href="http://www.napit.org.uk">www.napit.org.uk</a>	0870 444 1392
NICEIC Group Ltd	<a href="http://www.niceic.org.uk">www.niceic.org.uk</a>	0800 013 0900

### **Health and Safety Precautions**

#### **Handling**

Adequate facilities must be available for loading, unloading and site handling.

#### **Fire Cement**

Some types of fire cement are caustic and should not be allowed to come into contact with the skin. In case of contact, wash immediately with plenty of water.

#### **Asbestos**

This stove contains no asbestos. If there is a possibility of disturbing any asbestos in the course of installation then please seek specialist guidance and use appropriate protective equipment.

#### **Metal Parts**

When installing or servicing this stove, care should be taken to avoid the possibility of personal injury.

## **Installation**

### **Chimney**

The chimney height and the position of the chimney terminal should conform to Building Regulations.

Check that the chimney is in good condition, dry, free from cracks and obstructions. The diameter of the flue should not be less than 150mm and not more than 230mm. If any of these requirements are not met, the chimney should be lined by a suitable method.

The chimney must be swept before connection to the stove.

Where the chimney is believed to have previously served an open fire installation, it is possible that the higher flue gas temperature from the stove may loosen deposits that were previously firmly adhered, with the consequent risk of flue blockage. It is therefore recommended that the chimney be swept a second time within a month of regular use after installation.

If you have any doubts about the suitability of your chimney, consult your local dealer/stockist.

If there is no existing chimney then either a prefabricated block chimney in accordance with Building Regulations Approved Document J, or a twin-walled insulated stainless steel flue to BS 4543 can be used. These chimneys must be fitted in accordance with the manufacturer's instructions and Building Regulations.

### **Flue Draught**

A flue draught of minimum 1.2mm to a maximum 2.5mm water gauge is required for satisfactory appliance performance. The flue draught should be checked under fire at high output. If it exceeds the recommended maximum, a draught stabiliser must be fitted so that the rate of burning can be controlled and to prevent over firing. If the reading is less than the recommended minimum then the performance of the appliance will be compromised.

### **Connection to the Chimney**

An existing fireplace opening can be bricked up or sealed with a register plate. A short length of flue pipe of a minimum 152mm internal diameter may then be used to connect the stove to the chimney. This flue pipe should be of 316 grade stainless steel or vitreous enamelled, nominal thickness 1.2mm. Ensure that the pipe end is no closer than 76mm to the side or rear chimney walls.

Ideally, the old fireplace should be filled in so that there is a smooth streamlined entry into the flue way.

The length of any horizontal run of flue pipe must not exceed 152mm.

It is essential that all connections between the stove and chimney-flue are sealed and made airtight. Both the chimney and flue pipe must be accessible for cleaning and if ANY parts of the chimney cannot be reached through the stove (with baffle brick removed), a soot door must be fitted in a suitable position to enable this to be done.

### **Air Supply**

The room or space containing this appliance needs a permanent, unobstructed air opening of at least 4950 mm<sup>2</sup>.

If a draught stabiliser is fitted, the air opening should be at least 9150 mm<sup>2</sup>. Due consideration should be given to air requirements for any other appliances in the same room or space.

## Material Clearances

The stove can be recessed in a suitable sized fireplace but a permanent free air gap of at least 150mm must be left around the sides and top and at least 50mm at the back of the stove to obtain maximum heat output and for access to the rear of the stove.

All non-combustible walls closer than 300mm to the stove should be at least 75mm thick.

In all instances the hearth should be made of non-combustible material.

Allow an apron of at least 300mm at the front of the stove and 150mm on either side.

The hearth on which the stove is to be placed should not be less than 125mm thick and should be in accordance with the current building regulations.

Care should be taken to level the stove using the adjusting screws in the feet.

The appliance shall be installed on a floor with adequate load-bearing capacity. If the existing construction does not meet this prerequisite, suitable measures (e.g. load distributing plate) should be taken to achieve it.

MINIMUM DISTANCE TO COMBUSTIBLE MATERIAL	
Behind the stove	150mm
At the side of the stove	150mm

There should be **NO** furniture placed within a distance of **900mm** from any surface of the stove.

Note: combustible material refers to any material that will degrade when subjected to heat e.g. plaster.

## Material Clearances

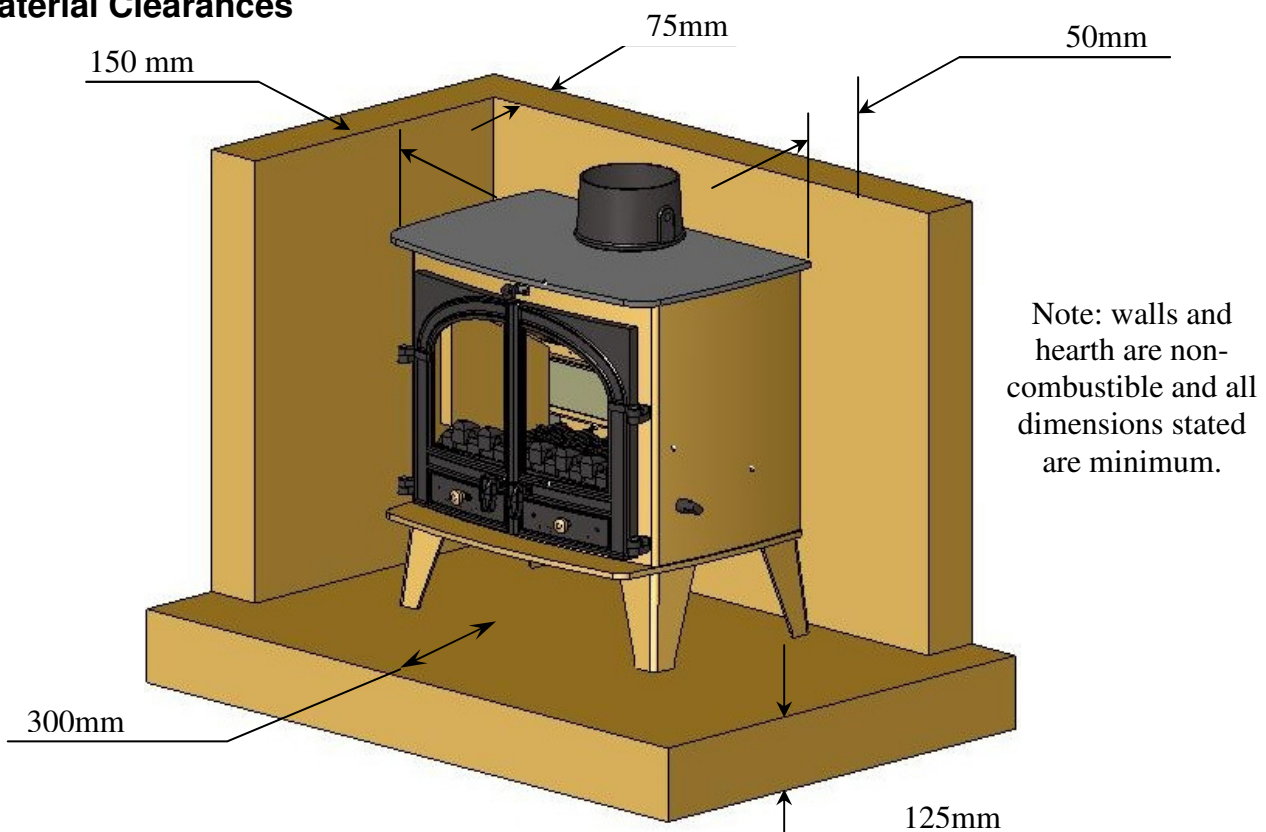

## INSTALLATION OF BOILER MODELS

We strongly recommend that a knowledgeable, experienced and qualified plumbing and heating engineer is responsible for the design and installation of the heating and hot water system. Parkray Ltd cannot accept responsibility for any consequential loss, however caused, due to under or over specification of the appliance in any installation.

**Do Not** – Under any circumstances connect the stove to a sealed (pressurised) heating system or unvented hot water cylinder.

**Do Not** – Link the stove into a heating or hot water system with an existing boiler without the use of suitable equipment such as a neutralizer. When fitting this type of system the neutralizer manufacturers instructions must be followed.

**Do** – Fit an open cold feed and expansion cistern with separate cold feed and vent pipes. The cold feed and vent pipes must be unvalved. The open vent pipe should have a diameter of 22mm and rise continuously from the boiler. It is common practice to form the vent pipe from an extension of the primary flow (see diagram).

**Do** – Connect the stove to a **double feed, indirect** hot water cylinder via 28mm copper flow and return pipework, rising continuously from the boiler to the cylinder. The cylinder and heat leak radiator must be sited higher than the stove.

Semi pumped systems should be used on heating and hot water systems with gravity circulation to the hot water cylinder and one unvalved 2 KW radiator to act as a heat leak when the central heating is switched off.

All four tappings on wraparound boilers should be used for systems incorporating separate gravity and pumped heating loops. Each flow and return should be taken from diagonally opposite sides of the boiler.

If a common flow and return is used, these should also be taken from diagonally opposite sides of a wraparound boiler, and plugs inserted into the sockets not used.

Systems using a common flow and return to the boiler should incorporate an injector tee on the primary return connection from the central heating pump (see diagram).

A HIGH LIMIT thermostat should be fitted to the gravity flow pipe close to the boiler and set at 90°C. This should override any pump control, switching the pump on and dissipating any excess heat around the radiator circuit.

To prevent boiler corrosion due to condensation it is necessary to maintain the return water temperature above 45°C. This can be achieved by the use of a LOW LIMIT thermostat on the return pipe from the hot water cylinder, close to the boiler. The thermostat should make on temperature rise, preventing the circulating pump from operating until the gravity circuit is up to temperature.

## Commissioning and Handover

Upon completion of the installation, allow a suitable period of time for any fire cement and mortar to dry out. A small fire may then be lit and checked to ensure the smoke and fumes are taken from the stove up the chimney and emitted safely to atmosphere. Do not run the stove at full output for at least 24 hours.

On completion of the installation and commissioning, ensure that the operating instructions and operating tools for the stove are left with the customer. Ensure to advise the customer on the correct use of the appliance with the fuels likely to be used on the stove and warn them to use only the recommended fuels for the stove.

Advise the user on what to do should smoke or fumes be emitted from the stove.

The user should be warned to use a fireguard to BS 6539 in the presence of children, aged and/or infirm persons.

## Four Tapping System

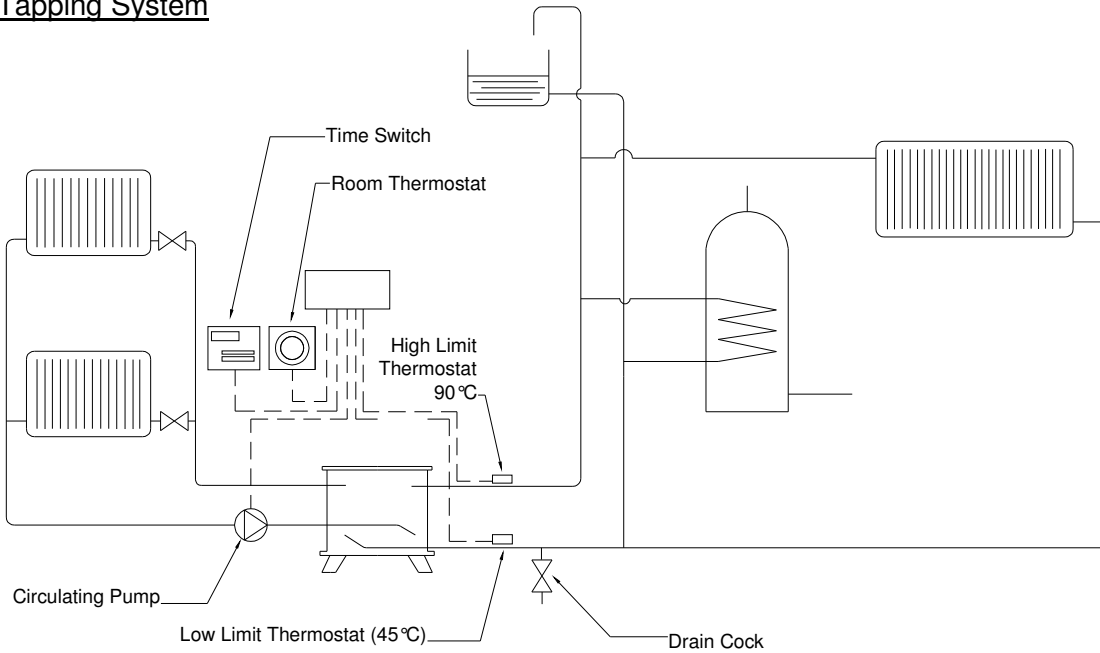

## Two Tapping System

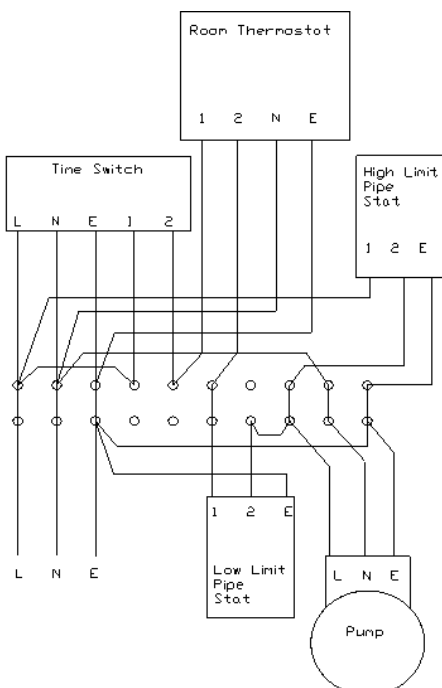
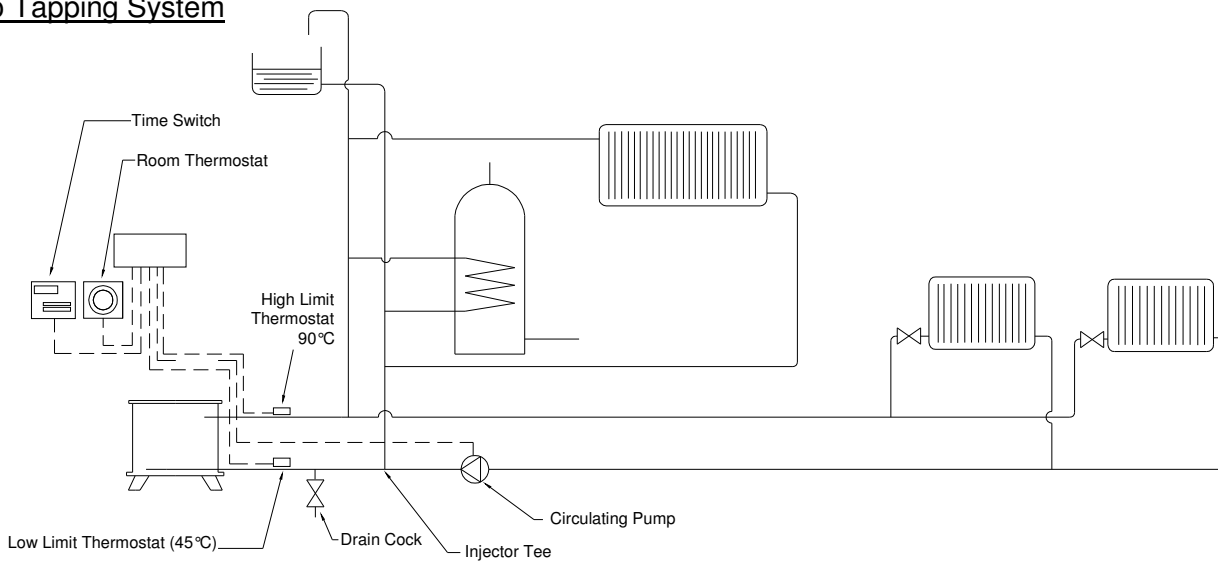

### Wiring Diagram for general guidance only

All electrical work must be carried out by a competent electrician in accordance with the rules in force and the instructions provided by the circulating pump and heating controls manufacturer



## Operating Instructions

This appliance is **not** suitable for use in a shared flue  
This appliance should **not** be operated with the doors open

### Aerosol Sprays

Do not use an aerosol spray on or near the stove when it is alight.

### Air Controls

This stove has been designed to burn cleaner and more efficiently than a conventional wood burning stove. If used correctly this stove will burn far more efficiently than normal with the obvious notable feature of CLEAN GLASS.

However, for this product to work properly it must be used correctly.  
It is essential that the stove has an adequate air supply for combustion and ventilation.

The primary and secondary air inlets must be kept clear from obstruction and blockage.

### Air Controls

Secondary Air Control (Open Right)

#### **Primary Air**

*The thermostat at the rear of the stove controls the primary air. The door sliders should be kept closed or the thermostat will not be able to control the fire.*

#### **Secondary Air**

*Secondary air is controlled via the slider above the doors; it is this "Airwash" that keeps a clean and uninterrupted view of the fire.*

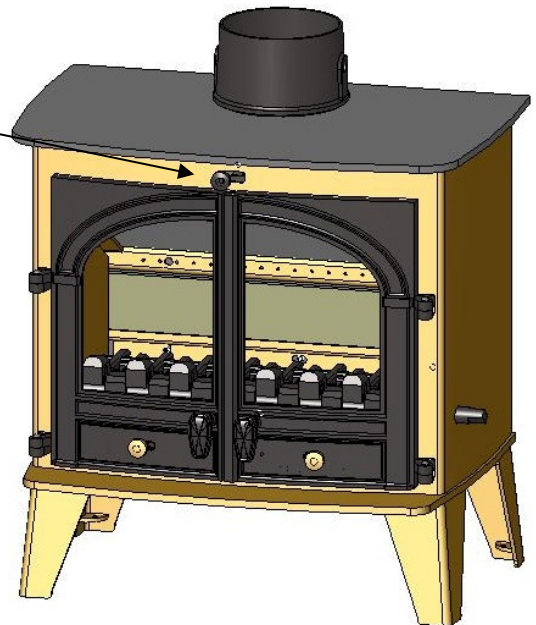

**Warning!** This Appliance will be **hot** when in operation and due care should be taken. The riddling tool may be used to operate the door handle. Thick gloves could be used to operate the primary and secondary air controls.

### Damper Assembly (Optional)

When burning wood, the flue damper assembly may be fitted. When the damper is set in the open position the chimney draws at full draught, increasing the volume of airflow through the stove and flue. Shutting the damper restricts the flow, slowing the rate of burning.

**Warning!** The flue damper must not be fitted when burning solid mineral fuel.

## Multifuel Grate

Your Parkray Stove is fitted with a locomotive type grate. So that de-ashing can be carried out cleanly and easily, it is riddled from the outside of the stove with the doors closed. The grate is designed to burn both wood and solid fuels.

**To burn solid mineral fuels** place the operating tool over the riddling spigot and pull it down towards you. When left in that position, air is directed under and up through the slots in the firebed, giving the optimum conditions for burning solid fuels.

It is important that the riddling tool is used to remove the ash to ensure airflow through the firebed and allow the fire to burn over the entire area of the grate.

The ashpan should be emptied at least daily and ash should never be allowed to build up over a period of time as this will result in damage to the fire bars. The flat end of the riddling tool can be used to carry the ashpan.

**To burn wood**, push the operating tool up and away from you. When left in this position, air is restricted through the bed of the fire providing a solid base to build up a bed of ash. Surplus ash can be removed either by gentle riddling or with a shovel.

It might prove beneficial when burning more reactive fuels to leave the grate in a “neutral” position, thus directing some under fire air and some over fire air to the firebed.

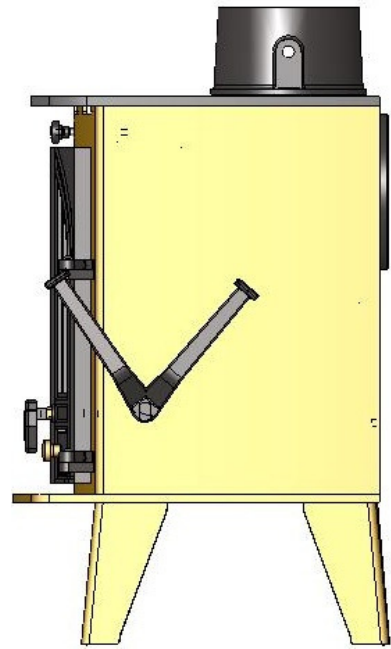

## Notes on solid mineral fuel burning

Solid mineral fuel should be placed in the stove so that there is no more than a 30° incline of the fuel bed from front to back. It should **not** be stacked above the level of the rear firebrick as this may result in damage to the stove.

With a full load of fuel, the stove will need to be refuelled approximately once every 4 hours.

Solid mineral fuel burns most efficiently with the secondary air control in the closed position. The primary air sliders can then be used to control the burn rate of the stove. For optimum performance when burning only solid-mineral fuel, it may also be beneficial to close the tertiary air cover plate on the back of the stove.

Always de-ash before refuelling and do not let the ash build up to the underside of the grate bars. Solid mineral fuel produces ash, which if allowed to build up will stifle the airflow through the Primary air sliders and grate. This will eventually cause the fire to die.

With some solid mineral fuels a residue of burnt fuel or clinker will accumulate on the grate, allow the fire to go out periodically to remove this.

**Important!** - We cannot stress firmly enough how important it is to empty the ashpan regularly. Air passing through the firebed cools the grate bars. Distortion or burning out the grate bars is nearly always caused by ash being allowed to build up to the underside of the grate.

## Notes on Wood burning

With a full load of wood, the stove will need to be refuelled approximately once every 1.5 hours.

Wood can be stacked higher in the stove than solid mineral fuel but care must be taken that logs do not touch the brick baffle.

Wood burns most efficiently with the primary air sliders in the closed position and the secondary control open. Moving the secondary control will control the burn rate of the stove.

Note - primary and secondary air is needed to light the stove, see section entitled 'Lighting the Stove'

Wood burns best on a bed of ash and it is therefore only necessary to remove surplus ash from the stove occasionally.

Burn only dry, well-seasoned wood, which should have been cut, split and stacked for at least 12 months, with free air movement around the sides of the stack to enable it to dry out. Burning wet or unseasoned wood will create tar deposits in the stove and chimney and will not produce a satisfactory heat output.

## Lighting the Stove

We recommend that you have two or three small fires before you operate your stove to its maximum heat output. This is to allow the paint to cure steadily and to give a long service life of the paint finish. During this curing in process you may notice an unpleasant smell. It is non-toxic, but for your comfort we would suggest that during this period you leave all doors and windows open.

First, load the fire with starting fuel, i.e. paper, dry sticks and/or firelighters in the mode chosen, either wood or solid mineral fuel.

Light the fire at the base leaving all air controls open. Allow the fuel to reach a steady glow and build the fire up gradually. Once you have a good fire established across the grate bed, further fuel can be added as required.

## Extended burning

The stove can be banked up for extended burning. When burning solid fuel, empty the ashpan. Open air controls and let the fire burn brightly for a short period. Refuel and close primary and secondary air controls, the exact setting required will depend on the fuel used and the chimney draw so some practice may be necessary. It may also be necessary to adjust the tertiary air cover plate on the back of the stove. To revive the fire, open the air controls until the fire is burning brightly de-ash if necessary and refuel. Set air controls as required.

## Reduced Combustion

In order to reduce the combustion of the fire to a minimum, close the primary air sliders, then close the secondary air slider by moving the handle all the way to the left. If the controls are left in this position, the fire will receive the minimum of air and will die down. If you want to revive the fire it is recommended that the primary air control is open first, then open the secondary air slider.

**Warning!** - The stove will remain **hot** for a considerable time after the fire has been extinguished.

## Recommended Fuels

Anthracite is an approved *natural* smokeless fuel (not *processed*) and therefore can vary greatly in quality and performance. It generally requires excellent air supply and above average fire-bed temperatures to maintain maximum performance and with experience we would suggest that it is used in conjunction with other approved *manufactured* smokeless fuels as per the HETAS approved list.

HETAS Ltd. approve the following fuels in closed appliances:-

Coalite	Ancit
Coalite Nuts	Taybrite
Blazebrite	Sunbrite Doubles
Homefire	Maxibrite
Homefire Ovals	Anthracite Small Nuts
Phurnacite	
Mixed Nuts	Wood Logs

Approval does not cover the use of other fuels either alone or mixed with the suitable fuels listed above, nor does it cover instructions for the use of other fuels. Only authorised smokeless fuels may be used in smoke control areas.

**Warning!** - Petroleum coke fuels or household waste must not be burnt on this appliance. This appliance should not be used as an incinerator. No liquid fuels should be burnt on this appliance. Should any difficulties arise over fuel quality or suitability, consult your local approved coal merchant or:

HETAS Ltd – Telephone 01242 673257 – [www.hetas.co.uk](http://www.hetas.co.uk)

Solid Fuel Association – Telephone 0800 600 000 – [www.solidfuel.co.uk](http://www.solidfuel.co.uk)

## Safety notes for your guidance

**FIRES CAN BE DANGEROUS** – Always use a fireguard in the presence of children, the elderly or the infirm. The fireguard should be manufactured in accordance with BS 6539 – Fireguards for use with solid fuel appliances.

**DO NOT OVERFIRE** – it is possible to fire the stove beyond its design capacity, this could damage the stove, so watch for signs of overfiring – if any part of the stove starts to glow red, the fire is in an overfire situation and the controls should be adjusted accordingly. Never leave the stove unattended for long periods without first adjusting the controls to a safe setting – careful air supply control should be exercised at all times.

## WARNING – FUME EMISSION

Properly installed and operated, this appliance will not emit fumes. Occasional fumes from de-ashing and refuelling may occur. Persistent fume emission must not be tolerated.

If fume emission does persist, then the following immediate action should be taken: -

1. Open doors and windows to ventilate room.
2. Let the fire out, or eject and safely dispose of fuel from the appliance.
3. Check for flue chimney blockage and clean if required.
4. Do not attempt to re-light the fire until the cause has been identified and corrected.

If necessary, seek professional advice.

**Important!** – Do not fit an extractor fan in the same room as this appliance.

## IN THE EVENT OF A CHIMNEY FIRE

- Raise the alarm to let others in the house know.
- Call the Fire Brigade.
- Reduce the appliance-burning rate by closing all air controls.
- Move furniture and rugs away from the fireplace and remove any nearby ornaments.
- Place a fireguard or spark guard in front of the stove.
- Feel the chimney breast for signs of excessive heat.

If the wall is becoming hot, move the furniture away. Ensure that the Fire Brigade can gain access to your roof space in order to check this area for signs of fire spread.



## **GENERAL MAINTENANCE**

**NO** unauthorised modification of this appliance should be carried out.

This appliance requires regular maintenance by a competent engineer.

### **Brick Baffle**

This should be removed and cleaned at least once a month to prevent any build up of soot or fly ash that could lead to blocked flue ways and dangerous fume emission.

If the baffle brick is removed the chimney/flue way can be swept through the appliance.

### **Stove Body**

The stove is finished with a heat resistant paint and this can be cleaned with a soft brush. Do not clean whilst the stove is hot; wait until it has cooled down. The finish can be renovated with high temperature stove paint.

### **Glass Panels**

Clean the glass panels when cool with a proprietary glass cleaner. Highly abrasive substances should be avoided as these can scratch the glass and make subsequent cleaning more difficult. Wet logs on heated glass, a badly aimed poker or heavy slamming of the doors could crack the glass panels. The glass will not fracture from heat.

### **Firebricks**

In normal use, these can last for many years. It is possible however, to crack them if logs are continually jammed against them or if they are frequently struck with a poker.

Check periodically for seriously cracked bricks, which can be replaced with new; available from your dealer.

### **Door Catch**

Should the door catch require adjustment, to maintain the door seal, it is adjustable. By slackening the locking nut and turning the door handle one turn clockwise, you will achieve a tighter lock when the door is closed.

### **Rope**

Check the rope around the door and glass. If rope is becoming detached, use a proprietary rope glue to reattach it. If the rope is in a poor condition, a replacement rope kit may be ordered from the Parkray spares range.

## **Chimney and Flue ways**

It is important that the chimney, flue ways and any connecting flue pipe are swept regularly. This means at least once a year for smokeless fuels and at least twice a year for wood and other fuels. The baffle brick will need to be removed from its supports in order to sweep the chimney (see assembly instructions).

Only wire-centred sweeps' brushes fitted with a guide wheel should be used.

If it is not possible to sweep all parts of the chimney through the appliance, ensure there is adequate access to cleaning doors.

If the stove is fitted in place of an open fire, then the chimney should be swept one month after installation to clear any soot falls which may have occurred due to the difference in combustion between the stove and the open fire.

## **Gaskets**

All gasket used on this appliance are produced from a heat resistant material called Manniglas. Over time you may find that the gasket changes colour. This is due to a reduction in the pigment used in the manufacture of the product, and is no cause for concern.

## **Troubleshooting**

Fire will not burn

Check that:

1. The air inlet is not obstructed in any way.
2. Chimneys and flue ways are clear.
3. A suitable fuel is being used.
4. There is an adequate air supply into the room.
5. An extractor fan is not fitted in the same room as the stove.
6. Flue draught is above minimum level (see installation instructions).

Fire blazing out of control

Check that:

1. The doors are tightly closed.
2. The air controls are all in the closed position.
3. A suitable fuel is being used.
4. The glass retaining clips are not loose.
5. The door rope seals are in good condition
6. Flue draught is below maximum level (see installation instructions).

## STOVE SPARES

### RIGHT HAND DOOR

Right Hand Door  
(CH08/004)

Door Glass  
(CH08/028)

Glass Gasket  
(CH08/029)

Door Knob (CHC04/010)  
M8 Full Nut (FNFN08)  
Catch Shaft (HHR08/111)  
Circlip (FLRX07)  
M8 Full Nut (FNFN08)  
Catch (HMSS04/037)

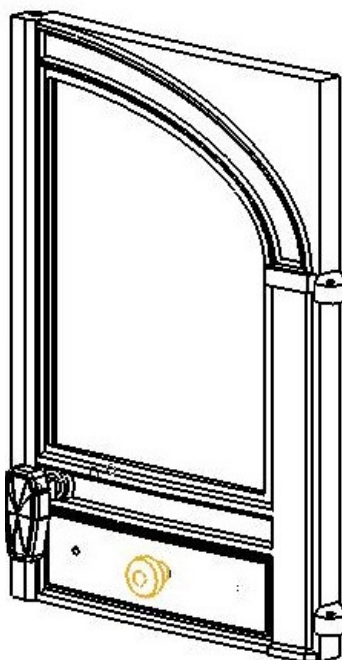

Glass Clip  
(HHR08/046)

Glass Clip Screw  
(FSJM05008SS)

Door Slider (CH06/006)  
Slider Knob (HHR08/045)

### LEFT HAND DOOR

Left Hand Door  
(CH08/005)

Door Glass  
(CH08/028)

Glass Gasket  
(CH08/029)

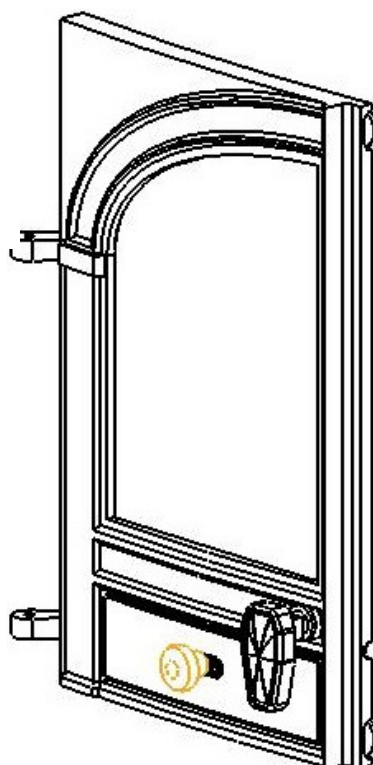

Glass Clip  
(HHR08/046)

Glass Clip Screw  
(FSJM05008SS)

Door Slider (CH06/006)  
Slider Knob (HHR08/045)

**STOVE BODY ASSEMBLY - PART SECTION - MULTIFUEL**

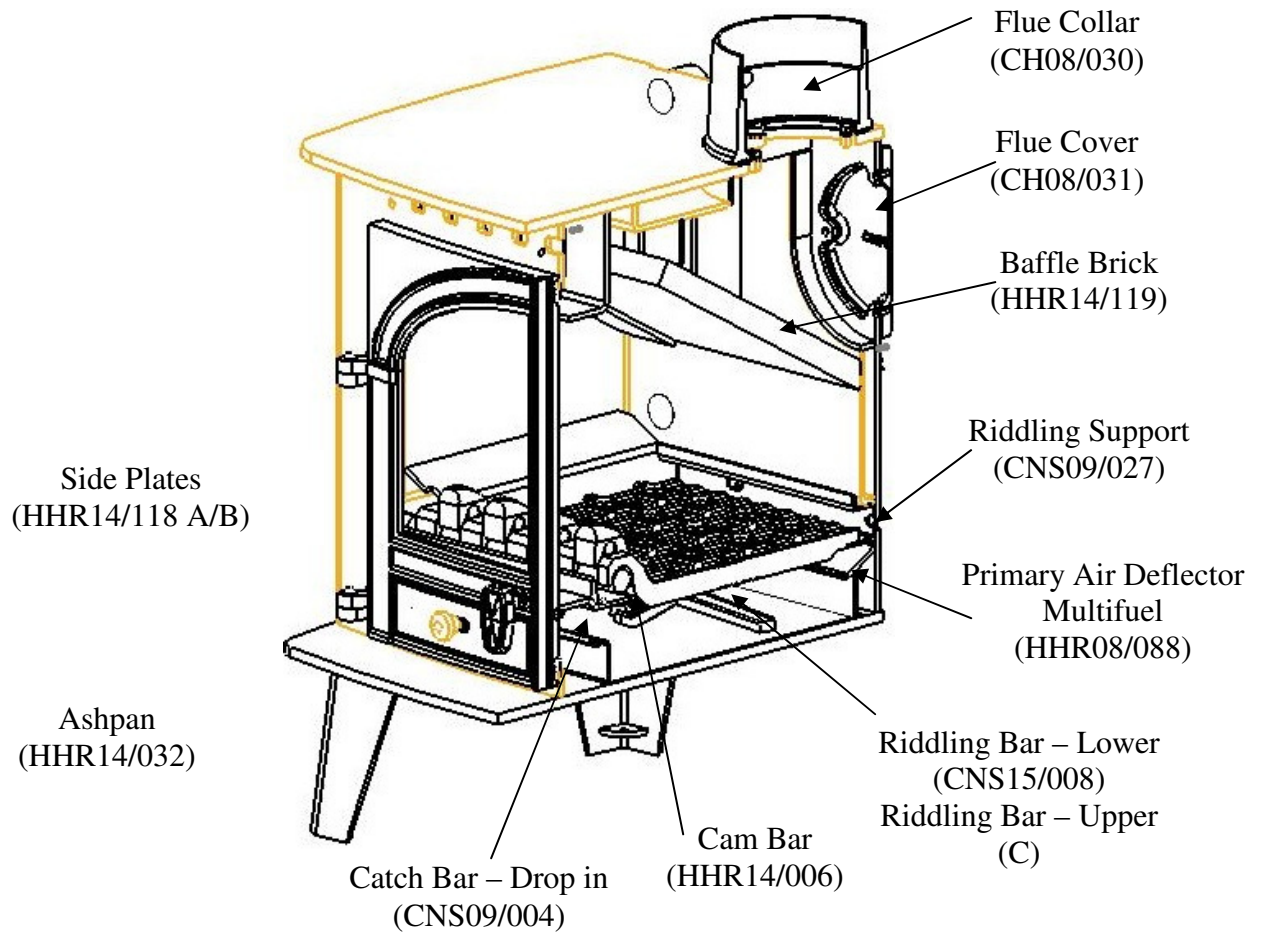

**STOVE BODY ASSEMBLY - PART SECTION - WOOD**

